



Sealing Rings for Dynamic Seals

Table of Contents

Page

Characteristic Properties	3
▪ Characteristic Properties for Seal Material used in Dynamic Seals	3
▪ Sealing Rings for Mechanical Seals	3
Sealing Rings for Mechanical Seals	4
▪ a) Grade Selection	5
▪ b) Application Limits	6
▪ c) Counterface Materials	7
▪ d) Machining of Sliding Surfaces Roughness – Surface Flatness	7
▪ e) Pressure Tightness of Carbon Sealing Rings	8
▪ f) Installation of Carbon Sealing Rings	8
▪ g) Fields of Application and Grade Recommendations	9
Carbon Seals for Steam Head Seals	10
▪ Carbon Seals for Steam Head Seals	10
▪ Grade Recommendations	10
Sealing Rings for Ball Valves	11
Sealing Rings for Radial Seals	12
▪ 1) Gap Seals	13
▪ Fields of Application	13
▪ a) Multisegment Rings	13
▪ b) Metal Clad Carbon Rings	14
▪ c) Labyrinth Rings	15
▪ 2) Contact Seals	16
▪ 3) Grade Selection	16
▪ Mating Materials	17
▪ 4) Back-up Rings	17
▪ 5) Design Recommendations	17
▪ 6) Design Examples for Multisegment Carbon Sealing Rings	18

Characteristic Properties

Characteristic Properties for Seal Material used in Dynamic Seals

The following characteristic properties of carbon and graphite materials have opened up wide fields of application for carbon and graphite sealing rings, e. g. in high and low temperature technology, in chemical and petrochemical industries, for the processing of food stuffs, pharmaceuticals and cosmetics, in pumps, compressors and turbines, in aircraft and automobile construction, in shipbuilding, in the paper processing industry, in air conditioning technology, in household appliances and in reactor technology.

- Sliding and dry running capacity, low coefficient of friction
- Wear resistance
- Chemical resistance
- Temperature resistance
- Good thermal conductivity
- Outstanding resistance to temperature cycling
- Excellent dimensional stability
- High fatigue resistance
- Favourable ratio strength/density
- No welding risk, contrary to metals when used as mating materials.

Please find further information on Schunk carbon and graphite materials for mechanical applications at www.schunk-tribo.com:

“Chemical Resistance”

“General Information; Properties, Application as Sliding Material, Design Recommendations”.

Sealing Rings for Mechanical Seals

The mechanical seal can be regarded as the main high-quality sealing element in use for the sealing of rotary shafts.

This rapid development of the mechanical seal as a machine element has only been possible through the continuous development of seal designs and through the systematic development of new and improved sealing ring materials.

This also includes the further development of carbon-graphite materials by Schunk Kohlenstofftechnik, which has made it possible to match increasingly severe operating conditions and thus the stricter requirements imposed on sealing ring materials.

In the development of new and improved grades of carbon for sealing rings not only the required material properties, but also the question of cost had to be taken into account, particularly for sealing rings in low-priced mass-produced seals.

Schunk Kohlenstofftechnik's material range extends from synthetic resin-bonded carbon grades through carbon-redensified carbon graphite and electrographite grades, carbon graphite and electrographite grades with various synthetic resin and metal impregnations to high strength electrographite grades with special impregnations to improve the oxidation resistance or the dry running capacity.

The properties of synthetic resin-bonded carbon grades have been improved considerably compared to carbon containing resin molding compounds. These grades are particularly suitable for the pressing-to-size of rings, even in fairly complicated designs, for mass-produced seals. In addition, a range of carbon graphite grades with the above mentioned impregnations are available which are also suitable for the pressing-to-size or partially pressing-to-size for mass-produced seals.

Sealing Rings for Mechanical Seals

Mechanical seals are mainly used for sealing between liquids and gases. It should be noted that, with carbon seal rings, even liquids with low hydrodynamic lubricating capacity provide sufficient lubricating effect.

The sealing of gases and the dry running that arises from this is possible at low sliding speeds with carbon sealing rings e. g. in agitator seals, provided that the wear rate is sufficiently low.

For the sealing of gases at high running speeds the use of carbon seal rings in so called gas seals is also common, provided that the design of the seal ensures that contact between the sliding surfaces can only occur at starting and stopping the machine. During normal running, the gas pressure ensures contact free operation of the sliding surfaces. Sealing between gases is carried out otherwise with double-acting mechanical seals and a sealing liquid, the sealing liquid serving as a lubricant for the sliding faces and for the dissipation of the frictional heat.

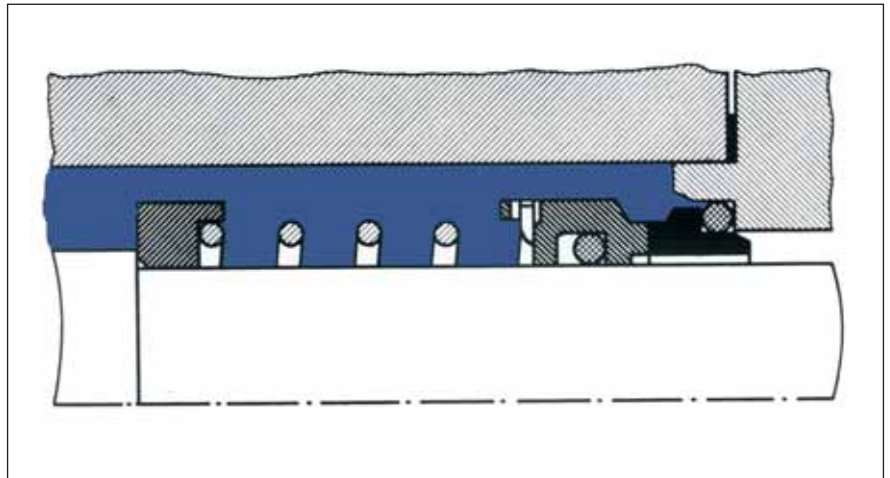

Unbalanced mechanical seal

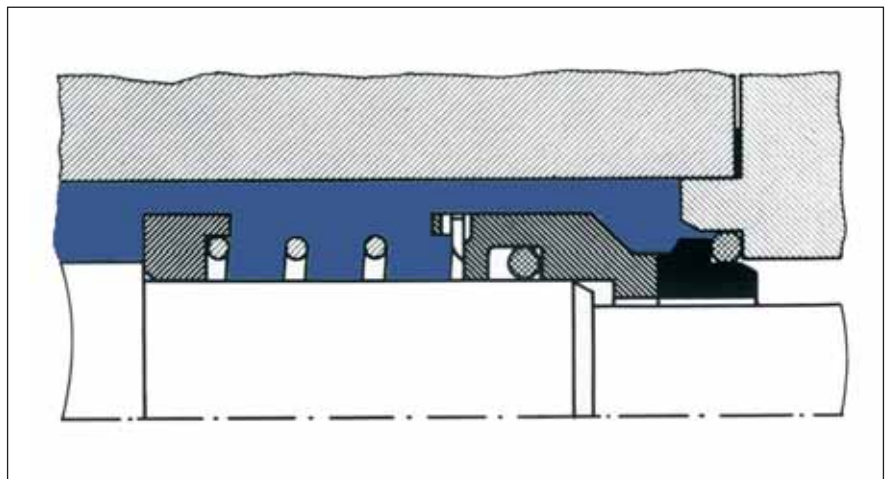

Balanced mechanical seal

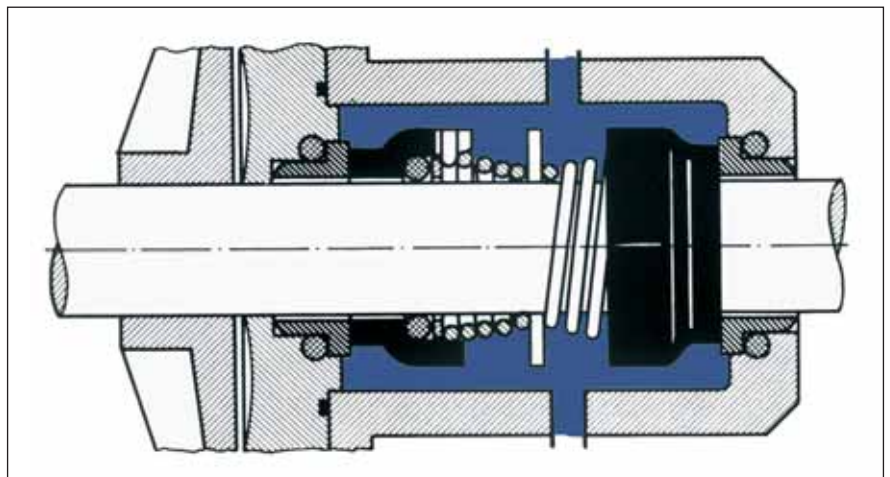

Schematic representation of mechanical seal designs

Double-acting mechanical seal

a) Grade Selection

It must be said that it is impossible to cover all service conditions with one carbon graphite material.

General Indications on Grades:

Synthetic resin-bonded carbon grades Examples: FF521	Wet running, low running speeds and loads, low chemical requirements
Carbon redensified carbon grades Examples: FH82Y5	Wet running, average running speeds and loads, highest chemical requirements
Synthetic resin-impregnated carbon grades Examples: FH44Z5, FH42Z5, FH82Z5	Wet running, average to high running speeds and loads, high chemical requirements
Metal impregnated carbon grades Examples: FH42A, FH82A	Wet running, up to highest running speeds and loads, limited chemical requirements
Electrographite and carbon graphite Examples: FH44Z2, FE45Y2	Dry running at low speeds
Examples of special materials: FH71ZH5, FH71A	Application in an absolutely dry environment



Seal rings
for compressors

b) Application Limits

Running speed:
70 m/s max.

Pressure difference:
160 bar max.

Sliding pressure:
10 - 200 N/cm²
generally < 50 N/cm²

Product of pressure and speed:
 $p \cdot v_{\max.} = 12,500 \text{ N/cm}^2 \cdot \text{m/s}$

The sealing ring wear is influenced much more by the sliding pressure than the sliding speed.

For many years Schunk Kohlenstoff-technik has carried out wear tests with standard and new developed grades. For such tests, 8 test rigs with 16 testing positions are used.



Test rigs for mechanical seals

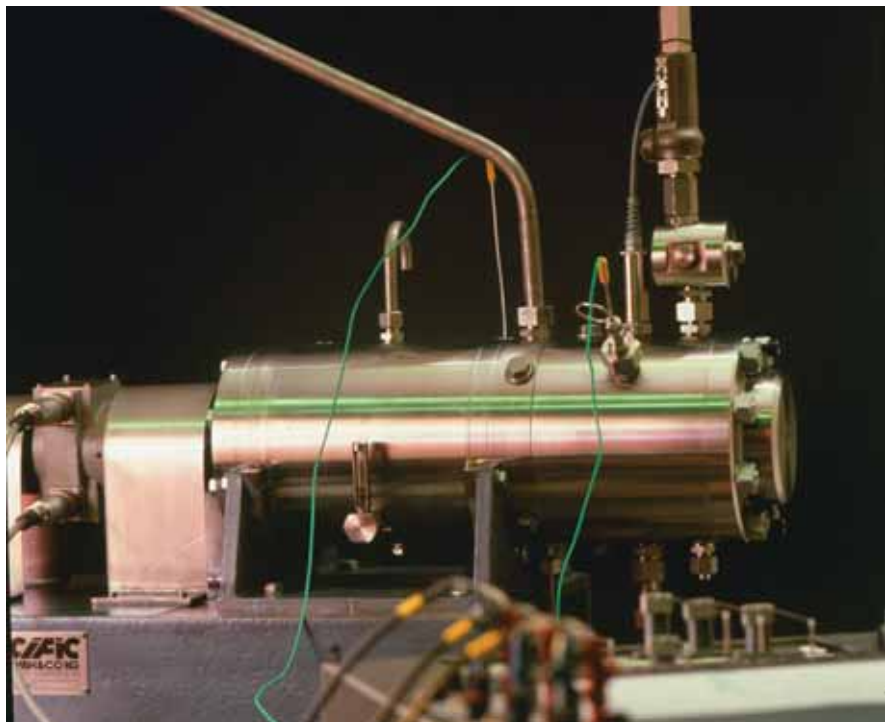

Testing stand for blister tests with high viscosity oils as the medium to be sealed off

c) Counterface Materials

The choice of materials for the mating component is of decisive importance for the operation of a mechanical seal. Three categories of mating materials for sliding rings of carbon graphite materials are summarized in the following table:

Counterface Materials

Suitable

- Cast iron
- Cast chrome steel
- Hardened chrome steel
- Tungsten carbide
- Chromium oxide (plasma coated)
- Silicon carbide materials
- Sintered ceramic (Al_2O_3) (only for wet running)
- Carbon graphite materials
- Silicon carbide/graphite composite material

Limited use

- Chrome nickel steel
- Austenitic cast iron
- Stainless sintered steel (impregnated with polyester resin)
- Stellite
- PTFE compounds
- Non ferrous metals

Unsuitable

- Aluminium
- Aluminium alloys (even if anodised)

d) Machining of Sliding Surfaces Roughness – Surface Flatness

The machining quality of the sliding surfaces is decisive for the seal or leakage and the wear of the sliding rings. Therefore, the sliding surfaces of seal rings have to be lapped, polished or superfinished.

Roughness of Sliding Surfaces

Carbon faces:
Ra 0.2 – 0.4 μm

Carbon sliding faces run-in rapidly on the counterfaces covering them with a graphite layer.

Lower roughness of the counterface impedes a rapid development of this friction and wear reducing, graphite layer.

Lower roughness of the counterfaces prevents from a fast formation of this friction and wear reducing transfer layer.

Surface Flatness of the Sliding Faces

Outer diameter of the sliding faces

< 80 mm
2 helium light bands
(approx. 0.6 μm)

> 80 mm
+ 1 light band
(approx. 0.3 μm)
for every 30 – 50 mm
increase in diameter.

The inspection of the surface flatness is effected by means of an optical glass and monochromatic light in an interference inspection apparatus, or with a laser interferometer.



Sliding surface with imperfect flatness



Perfectly flat surface

e) Pressure Tightness of Carbon Sealing Rings

Sliding rings made of redensified or impregnated carbon graphite material are impervious to liquids and gas.

An inspection of the pressure tightness can be performed at 3, 5 or 10 bar.

f) Installation of Carbon Sealing Rings

Usually, carbon sliding rings are installed in a push-fit seating over O-rings and in rubber or plastic sleeves, antirotation locking being provided for in each case.

Adhesive bonding is customary for installation in metal holders or metal bellows. The adhesive must be suited to the chemical and thermal requirements. Special attention must be given to the pressure tightness of the joint.

The same applies to press-in and shrink-in fits. Here, the following criteria are important. It is important to maintain tight dimensional tolerances particularly shape tolerances such as concentricity

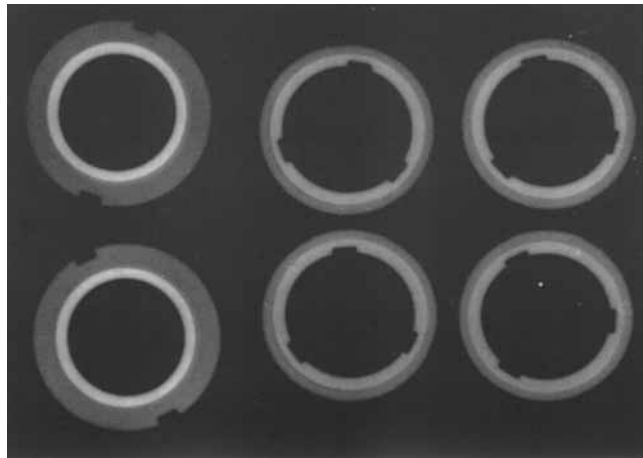

Coarse structure X-ray photograph of metal-impregnated carbon sealing rings

and conicity of both the bore and outside diameter.

Press-in fit: H7/s6

Shrink-in fits: H7/x8-zb8

The required crossover tolerance and shrinkage temperature for shrinkage fit are dependent on the holding material and operating temperature. Because of the changes in shape that occur during shrinking in, the flatness of the sliding surfaces can only be achieved by remachining after shrinking in.

Due to the lower shrinking stress at operating temperature, compared to room temperature, the sliding surface is no longer as flat over its whole width at operating temperature as it is at room temperature, resulting in a certain leakage until the running in of the sliding surfaces.



Carbon sliding rings with metal sleeve

g) Fields of Application and Grade Recommendations

The following table of application fields for mechanical seals with carbon graphite sliding rings cannot be comprehensive.

The indication of the Schunk grades for the various applications have to be considered as recommendations, based on success in service.

In special cases, other grades may be more suitable. Please contact our application specialists.

Fields of Application for Mechanical Seals	Grade Recommendations for Carbon Sliding Rings
Cold water pumps	FH421Z5, FH421A
Hot water pumps	FH82ZH5, FH82A
Industrial water pumps	FH42Z5, FH82Z5
Feed water pumps	FH82ZH5, FH82A, SiC30
Automobile cooling water pumps	FH421Z5, FH421A, FF541
Compressors for automobile air conditioning equipment	FH421A
Refrigeration compressors	FH82A, FH82ZH5, SiC30
Feed pumps for fuel and fuel oil	FH42A, FH82A
Oil-burner feed pumps	FH421A, FF521
Dishwasher lye pumps	FH421Z5
For aircraft construction	FE679Q, FH42AR, SiC30
In ship building stern	
Tube seals surface crafts and submarines	FH429A, FH829A, FH829Z5
Bilge pumps	FH42Z5, FH82Z5
Pumps and installations in the food industry	FH42Z5, FH82Z5
Chemical pumps	FH44Z5, FH42Z5, FH82Z5, FH82Y5, FE45Y2, FE45Z5
Pumps for petrochemistry	FH42A, FH82A
Agitators wet running	FH42Z5, FH82Z5, FH42A, FH82A
dry running	FH71Z5
Centrifuges	FH44Z5, FH42Z5
Compressors	FH82A, FH82ZH5
Thermal oil pumps	FH42A, FH82A
Pumps for power stations	FH82Z5, FH82ZH5, FH82A, SiC30
Primary cooling pumps for nuclear power stations	FH829Z5, FH829ZH5, SiC 30
Water turbines	FH27Z2, FH42, FH71ZH5
Pumps for liquefied gasses	FH42A, FH82A, FE45A



Gas seal

Carbon Seals for Steam Header Seals

Carbon Seals for Steam Header Seals

The steam header seal, or in more general terms the feeder head seal, represents a special form of mechanical seal.

When steam, hot or cooling water and thermal oil are fed to rotating rolls and drums, vibrations, wobbling and oscillatory movements can occur as well as the rotary motion.

Therefore the design of the feeder head seal must permit certain angular movements. In most cases, this is achieved through the use of carbon sealing rings having a convex or concave sliding surface. Feeder head seals, e. g. in the paper and pulp industry, have to run continuously and maintenance-free for long periods of time although the carbon graphite seal rings are subject to mixed friction, only lubricated by steam or even dry running.

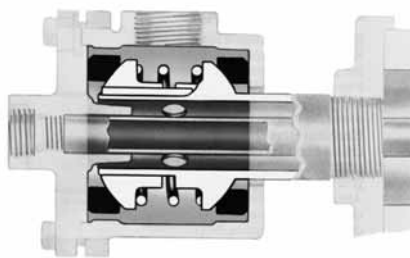

Steam header seal

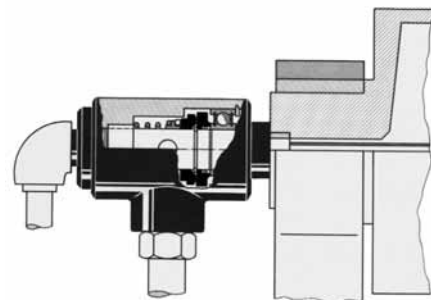

Feeder head seal

Usually the running speed with values of < 0.1 m/s is low, the load, however, can exceed 150 N/cm². Due to the resulting friction heat, the temperature in the sealing gap may exceed the saturation point of the steam and, consequently, there will be dry running.

It is therefore recommended to avoid setting the load too high and to accept a slight leakage of the non-toxic steam.

Spring load: $1-3$ N/cm²

Grade Recommendations

Steam:

FH27S, FH42, FH42A, FH44Y2, FH27Z2, FH44Z2

Cold water:

FH44Z5, FH42Z5

Hot water:

FH42A, FH44ZH5, FH42ZH5

Thermal oils:

FH42A, FH82A

Most of the indications given in the foregoing chapter "Sealing Rings" are also valid.



Carbon sealing rings for steam header seals

Sealing Rings for Ball Valves

Sealing Rings for Ball Valves

Ball valve seals of carbon graphite material are in use for fire-safe ball-valves for oil refineries and oil tankers and for high temperature ball valves for chemical industries. Seal rings of carbon graphite material are in use for the sealing of hot steam and gas, i. e. beyond the capacities of conventional materials such as PTFE compounds etc.

Roughness of counterfaces:
 $R_t \leq 1.5 \mu\text{m}$

Grade recommendations:
FE45A, FH42A

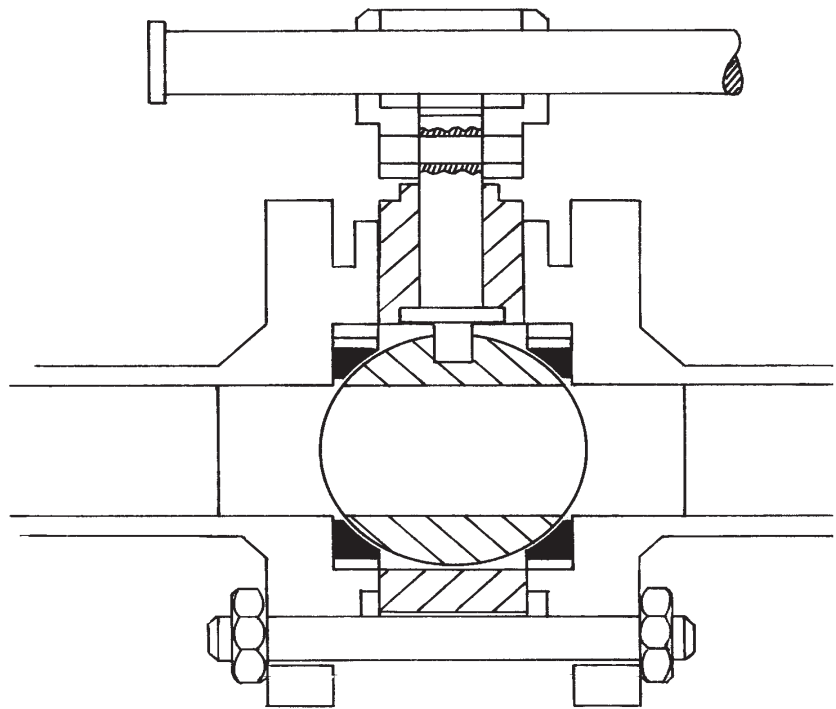

Ball valve seal

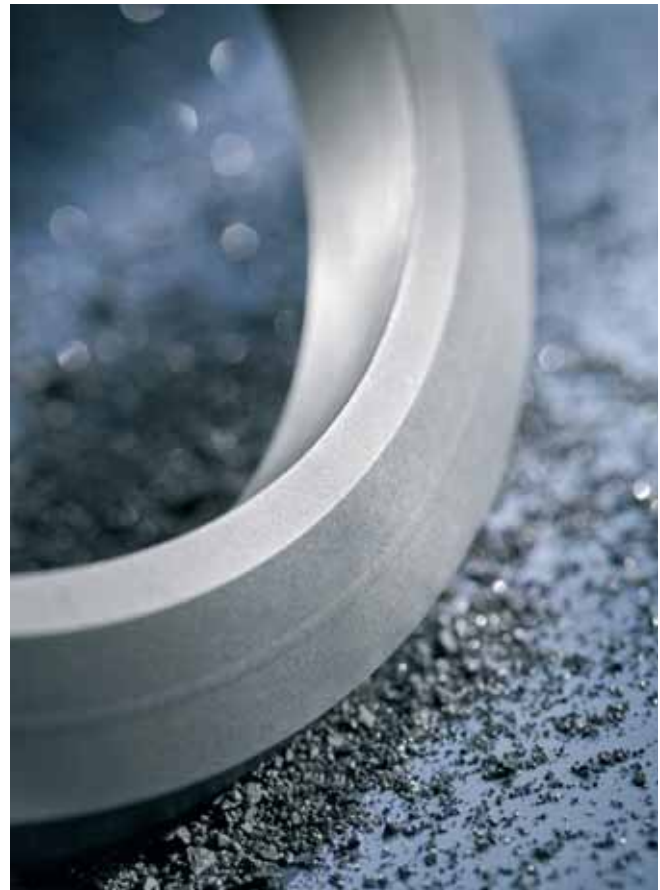

Sealing Rings for Radial Seals



Multi part carbon ring for radial shaft sealing

Because of their characteristic properties (see chapter 1) carbon/graphite sealing rings have been successfully used for many years in radial seals, both with rotary and oscillatory motions.

Apart from carbon sealing rings encased in metal, multipart carbon sealing rings composed of segments are mainly used for radial seals.

The multi-part construction is necessary, because carbon and graphite materials cannot deform elastically like other sealing

materials for radial seals. In addition, the multipart construction simplifies assembly.

Depending on the size of the rings, they are divided into 3, 4, 6, 8, 12 or more segments. In order to secure an optimal assembly and thus a maximum sealing effect the individual ring segments are numbered. Multi-part carbon sealing rings are pressed against the shaft or piston rod by garter springs.

Recommended surface pressure:
1 – 1.5 N/cm²

Garter springs out of stainless steel 1.4310 have proved satisfactory.



Fracture segmented ring (patented)

Dimensioning of Multi-part Carbon/Graphite Sealing Rings

$$D = 1.2 \text{ to } 1.5 \times d$$

$$b_{\min} = 8 \text{ mm with butt and overlapped joint}$$

$$b_{\min} = 10 \text{ mm with overlapped mortise joint}$$

$$h \approx 0.15 \times d$$

$$h_{\min} = 6 \text{ mm with butt and overlapped joint}$$

$$h_{\min} = 8 \text{ mm with overlapped mortise joint}$$

$$r = \frac{\text{Outside diameter of spring}}{2} + 0.3 \text{ to } 0.5 \text{ mm}$$

$$s \approx \text{depending on the type of seal, the shaft diameter and number of segments in the ring}$$

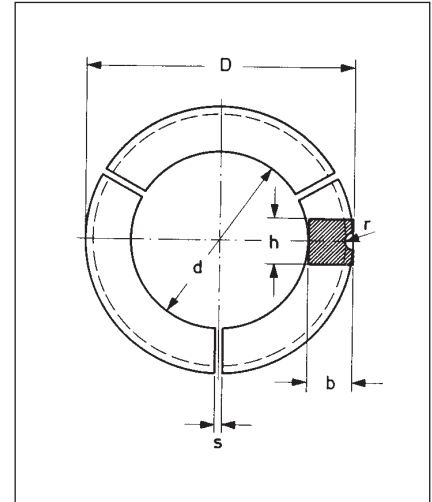

1) Gap Seals

Gap seals are used with both rotating and reciprocating motions.

A gap seal is always preferable to a contact seal if excessive wear is to be expected with a contact seal because of the operating conditions. This mainly applies for high sliding speeds and high loads where, in the case of a contact seal, excessive heating can occur at the sealing faces, resulting in excessive wear.

Both one piece carbon rings, encased in metal holders, and segmented sealing rings are used in gap seals.

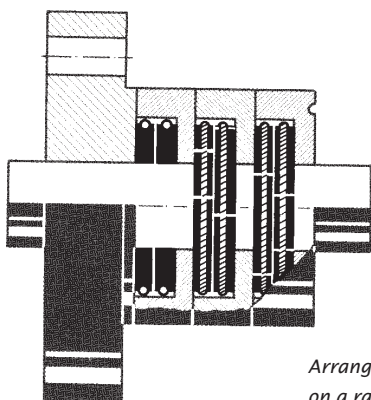

Arrangement of multi-segment rings on a radial shaft seal.

Fields of Application

Typical fields of application for gap seals are steam turbines, piston rod glands of oil-free piston compressors, screw type compressors and axial-flow compressors in general.

a) Multisegment Rings

With multisegment carbon graphite sealing rings, tight tolerances for assembly are not necessary.

When installed, the rings must have a certain clearance at the segment joints, so that, under the pressure of the garter spring, they work initially as contact seals.

It is only after slight wear during running-in that the joint clearance becomes zero and the seal can run practically as a gap seal, with minimum gap losses and consequently high sealing effect. The adjustable orientation of multi-segment rings in chambers is advantageous for compensation of radial shaft displacement.



Different carbon ring segments

With butt jointed sealing rings it is preferable to arrange two rings in a chamber with the joints staggered in relation to one another in order to achieve a good axial seal. Even with carbon sealing rings with overlapped or overlapped mortise joints, this arrangement of the rings in pairs in chambers gives an improvement in axial sealing. For rotation prevention the rings are usually pinned to one another or to the chamber ring.

b) Metal Clad Carbon Rings

With one piece carbon graphite sealing rings, a sufficiently tight seal gap over a wide temperature range can only be achieved by correspondingly tight assembly tolerances and the special procedure of shrinking into a metal holder.

It is the lower coefficient of thermal expansion of carbon graphite material compared to steel which necessitates its shrinking into a metal holder.

The metal clad rings are under shrinkage stress and expand in correspondance to the coefficient

of thermal expansion of the metal holder material.

The shrink fits and the shrinking in temperatures have to be selected in accordance with the maximum service temperature.

Customary shrink fits and shrinking in temperatures:

H7/z8-zb8

The required shrinkage temperature is dependent on the holding material used.

To be observed when shrinking into metal holders:

- subsequent machining of the ring bore
- according to required tolerances subsequent machining of the outer diameter of thin walled steel holders ($\approx 0,3$ mm oversize for machining).

Schunk Kohlenstofftechnik supplies the majority of metal clad carbon rings ready for installation.

In case of metal clad carbon rings for valves, the periphery of the metal holder is provided with a thread.

In most gap seals, depending on the pressure drop (see design recommendations), several rings are arranged behind another in steel or cast iron chamber rings.

Due to the pressure drop the rings are pressed axially against the face of a chamber ring resulting in additional axial sealing.

The pre-condition is that the chamber face is well machined ($R_t \leq 2 \mu\text{m}$) and, as far as the metal clad carbon rings are concerned, that the carbon ring protrudes axially from the metal holder.



Metal clad carbon ring

c) Labyrinth Rings

Labyrinth rings are one piece or multisegment carbon graphite rings with labyrinth grooves or threads in the bore of the ring although they are rarely used in “classical” labyrinth seals.

The sealing effect of the labyrinth ring in gap seals is improved by the aforementioned grooves and threads.



Labyrinth ring

2) Contact Seals

Provision must be made in the design of the seal for adjustment of the rings as there will be wear taking place due to the continuous contact to the shaft or piston to be sealed.

This is made possible by using overlapped or overlapped mortise joints having a sufficiently large play at the intersegment face.

Such rings are used as choking rings for high-temperature applications and high chemical requirements, furthermore for water turbine seals and stern tube seals.

With segmented rings, the aforementioned adjustment can also be achieved by using unequal segments having tangential cuts and correspondingly tangential contact surfaces.

Here too it is useful to arrange the carbon sealing rings in pairs in chambers, with staggered joint gaps, in order to achieve a good additional axial seal. Again, the rings are pinned to one another or to the chamber ring, to prevent rotation.

Contact seals with such rings, however, can only be used with reciprocating motions, e. g. for the sealing of piston rods in dry running compressors

3) Grades Selection

Grades

Non-impregnated carbon graphite and electrographite grades are mainly used for carbon sealing rings in radial seals.	FH27S, FH42, FE45Y2, FE45Y2, FH44Y2
Synthetic resin impregnated grades have proved successful for more critical operating conditions.	FH27Z2, FE45Z2, FH44Z2
Metal impregnated grades should be selected for high pressure drops or the risk of erosion wear.	FE45A, FH44A



Multi part carbon ring for radial shaft sealing

Mating Materials:

All customary materials for shafts and piston rods.

Exceptions:

Aluminium, aluminium alloys and non-ferrous metals

With reservation:

Austenitic steel

Alternatives:

Hard chrome or hard nickel plating

Roughness of counterfaces:

$R_t \leq 2 \mu\text{m}$

4) Back-up Rings

The use of carbon graphite back-up rings is customary in contact seals with plastic sealing rings, e. g. made of PTFE or PTFE compounds.

The carbon support ring is mounted between the plastic sealing rings and with minimum play to the shaft or piston rod. This avoids flow of the plastic through the gap between the shaft/piston rod and the chamber ring under heat and pressure conditions.

The self-lubricating properties of carbon graphite materials prevent the shaft or piston rod surface from being damaged during a short-time contact of the carbon back-up rings.

5) Design Recommendations

The number of the carbon/graphite sealing rings to provide for in gap and contact seals depends on the service conditions, the seal type and the permissible amount of leakage.

From years of experience, the number of carbon sealing rings can be calculated roughly by the formula

$$n = 2 + k \times \Delta p$$

$k \approx 0.1$ for contact seals

$k \approx 0.2$ for gap seals



Split ring (segment)

6) Design Examples for Multisegment Carbon Sealing Rings

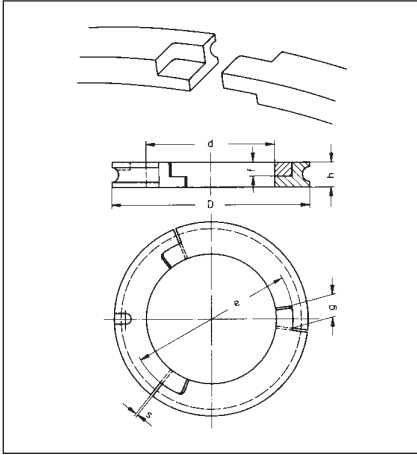

*With overlapped mortise joint
for shaft seal YFZ 54502*

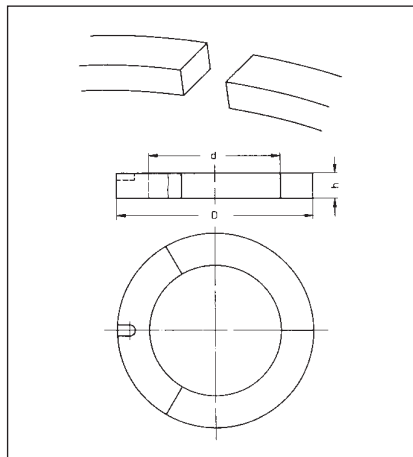

*With butt joint for shaft and
piston-rod seal YFZ 54500*

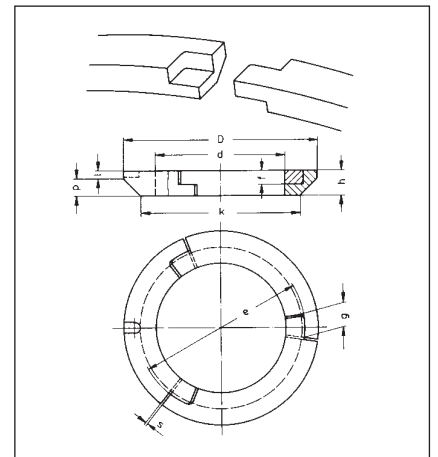

*With overlapped mortise joint
and external bevel for shaft seal YFZ54503*

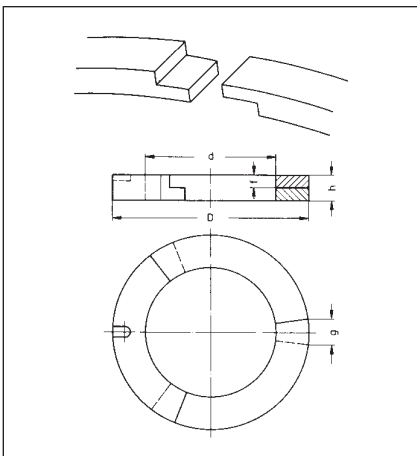

*With overlapped joint
for piston seal YFZ 54501*

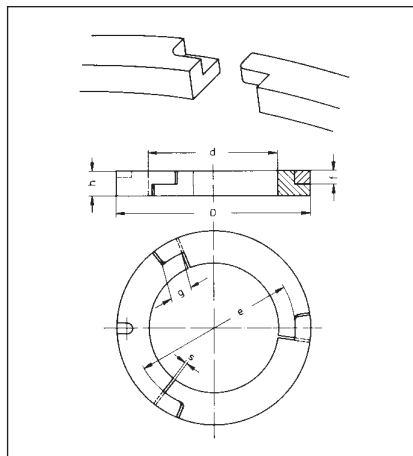

*With overlapped mortise joint
for piston seal YFZ 54504*

Schunk Kohlenstofftechnik GmbH

Rodheimer Strasse 59
35452 Heuchelheim, Germany

Telephone: +49 (0) 641 608-0
Telefax: +49 (0) 641 608-17 26

sse@schunk-group.com
www.schunk-tribo.com